



Door Operator Conversion Package:

Type M, PMSSC, HPM/SSC to Closed Loop

© 2005 KONE Inc.

Unpublished work. All rights reserved. No portion of this volume may be used or reproduced in any manner without written permission from KONE Inc. — One KONE Ct; Moline, IL 61265

Due to our policy of continuing improvement, we reserve the right to alter design and specification without prior notice. The right to make changes to product design and material use, without notice, is reserved. All hardware and software referenced in this publication and/or used in conjunction with equipment described herein is the exclusive property of KONE Inc. whether or not protected by U.S. and/or International Trademark, Copyright and/or Patent Laws.

DOOR OPERATOR CONVERSION PACKAGE

Type M, PMSSC, HPM/SSC to Closed Loop

Safety	4
Product description	5
Conversion of type M door operator	6
Wire microswitches - type M door operator	7
Conversion of PM/SSC, HPMSSC to closed loop 105 board	8
Install motor & control - type M, PM/SSC, HPM/SSC door operators	9
Install bottom cover	10
Install new cover	11
Verify microswitch cam settings	12
Wire closed loop door operator	13
Checking operation	16
Adjusting procedures for Closed Loop Door Control	18

Safety

Participate in the success of the installation of the closed loop door operator - know the safety hazards related to any procedure, know what equipment has been specified for each specific contract, and know what tools and materials you should plan to have available beforehand.

Before connecting electrical wiring, take precautions to prevent accidents from happening to yourself and other people around you. Always consider safety first.

- Wear safety glasses or goggles when using power tools.
- When working on the car canopy, always be aware of where the sides of the car are located.
- If step ladders are used, always support step ladder feet.
- Use properly grounded cords and power equipment (ground fault circuit interrupters).
- Make sure hoistways and work areas are adequately lighted.
- Make sure there are proper clearances in hoistway between the car and other devices.
- Always wear protective gloves when installing or removing access covers, conduits, wireway, or electrical devices.
- Before connecting wiring, cover sharp edges to keep hands and arms from being cut.
- Always disconnect power from all related circuits before proceeding with wiring-treat all circuits as if they are still live.
- Use insulated and grounded tools.
- Clear wiring sites of any unnecessary materials or equipment.
- Always know where other people are and how elevator wiring can affect their safety.

F608-031 (3/96)

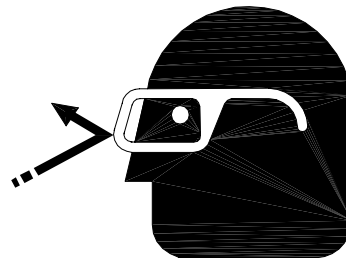

019(6/01)

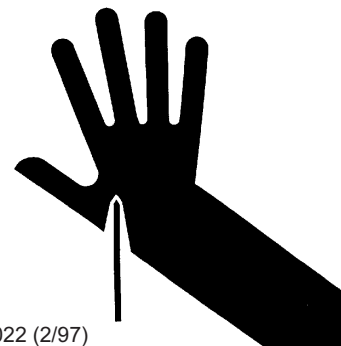

022 (2/97)

Product description

Closed loop door control is a microprocessor-based fully digital elevator door control system, continuously controlling all aspects of door motion including direction, velocity, acceleration and force. Closed loop door control includes following components and controls.

- Main PC board
- Motor control
- Current/torque control

MAIN PC BOARD

Main board contains all user connections, power converter, power supplies, adjustment switches, and an “Overseer” function that monitors door acceleration and control input.

MOTOR CONTROL

Closed loop door control utilizes a low voltage permanent magnet DC Motor powered by a fully controlled PWM (Pulse Width Modulated) converter operating at a very high frequency, (20,000 Hz). High frequency is well out of audible range and provides for quiet motor operation. Converter also includes full overcurrent sensing and electronic output short circuit protection circuitry.

PWM power delivered to motor is supplied in a series of voltage pulses. Each pulse has same amplitude, but varies in width. Motor responds to average pulse voltage, so by varying width of pulses, average motor voltage is either increased or decreased.

CURRENT/TORQUE CONTROL

Closed loop door control incorporates a closed loop controller continuously measuring current/torque in motor, and adjusting it as necessary to provide for proper acceleration and force required to move doors. It also regulates door closing force, which is adjustable through service tool. Current control also provides full overcurrent sensing, and proper system shutdown when faults occur.

F608-002 (6/98)

Conversion of type M door operator

1. Turn OFF electrical power to door operator.
2. Remove existing microswitch cover.
3. Remove all wiring and jumpers from microswitch
4. Remove and tag all controller wiring from terminal block.
5. Remove motor wires from terminal block, and remove terminal block and hardware.
6. Remove motor belt, and remove motor.
7. To install bottom cover, remove U-bolts holding the pivot shaft.
8. Slide the bottom cover in place and use the clips supplied to hold the cover in place.
9. Reinstall the pivot shaft to hold the bottom cover in place.
10. Install the flex conduit with controller wiring from the outside - in on the end of the base opposite the microswitches.

For more information on installing cover, refer to section titled: Install New Cover, in this document.

630-011 (2004-11)

Wire microswitches - type M door operator

1. Using the cable supplied, wire the microswitches as shown below.
 - If the DSD microswitch is required, add the switch.
 - If the DSD microswitch is not required, tape up the number 12 and number 13 wire.
2. Route the connector of the cable under the cams.

630-012 (2004-11)

- Wire Colors
- 1 = Black
 - 2 = Red
 - 3 = Yellow
 - 4 = Blue
 - 5 = Brown
 - 6 = Orange
 - 7 = Gray
 - 8 = Violet
 - 9 = White/Black
 - 10 = White/Red
 - 11 = White/Green
 - 12 = White/Yellow
 - 13 = White/Blue

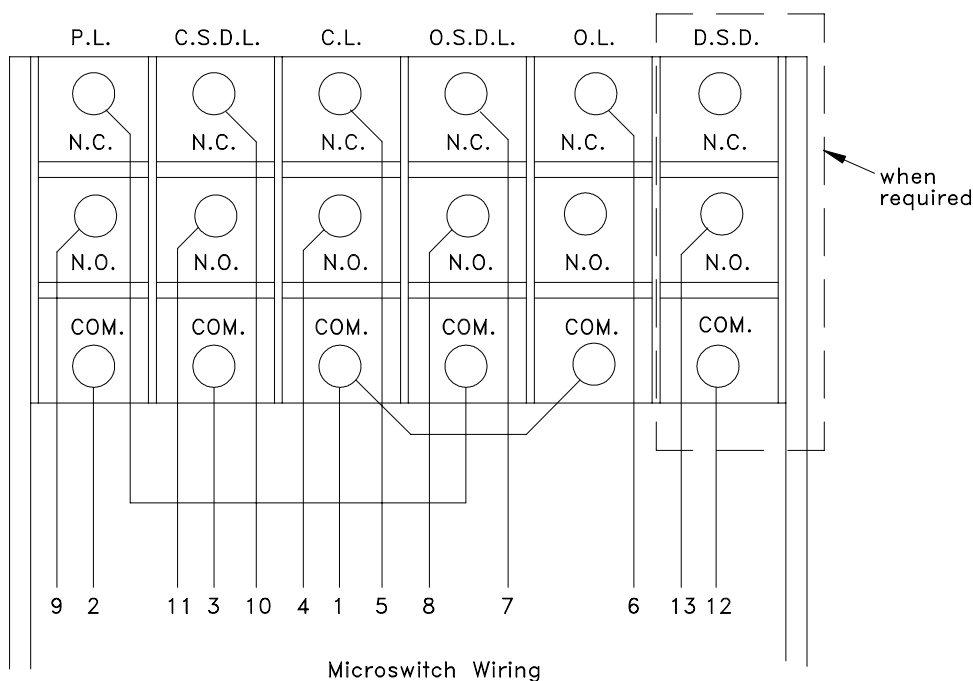

A603-124(4/93)

Conversion of PM/SSC, HPMSSC to closed loop 105 board

1. Turn OFF all power to the door operator.
2. Remove the cover(s) from the operator, or from the control and microswitch (if unit is an older style unit). Discard covers.
3. Remove and tag all wires at the main terminal strip.
4. If the control is the older style that has flex conduit connected directly to the control assembly, remove this from the control and reinstall in the end of the operator base.
 - ▶ The wires may need to be spliced to make them long enough to reach the new control board.
5. Disconnect the motor from the terminals A1 and A2 at the control board.
6. Remove the four motor bolts and remove the motor. Discard the belt.
7. Unplug the microswitch connector from the control board.
8. Push the connector of the microswitch cable through slot in the control. Lift the control and remove the microswitch cable from the control leaving the cable attached to microswitches.
9. Remove the control.
10. For older style controls with two small covers, install mounting hardware for the new cover.

For more information on installing cover, refer to section titled: Install New Cover, in this document.

630-013 (2004-11)

Install motor & control - type M, PM/SSC, HPM/SSC door operators

1. Set the control assembly in place on the operator, and route the microswitch cable through the slotted hole in the end of the control and up through the slot in the control base.
2. Install split bushings in the holes to guard the wires.
3. Plug microswitch cable into the 105 board.
4. Set the motor on the control, and secure with four 3/8-24 x 1 in. screws (HHCS) supplied. Do not completely tighten the screws.
5. Install the motor belt, set belt to proper tension, tighten the four screws that hold the motor and control to the base.
6. Replace drive belts with belts supplied with the kit.
 - The split link will have to be removed temporarily to replace the belts.
7. Install the encoder cable.
 - The end of the cable with the key in position number 2 connects to the motor encoder.
 - The other end of the cable connects to connector P-3 on the 105 board.

630-014 (2004-11)

Install bottom cover

1. To install bottom cover, remove U-bolts holding the pivot shaft.
2. Slide the bottom cover in place and use the clips supplied to hold the cover in place.
3. Reinstall the pivot shaft to hold the bottom cover in place.

630-015 (2004-11)

Install new cover

1. Drill two 21/64 inch [8.3 mm] diameter holes (8) in each end of the base assembly. (Two holes in each end of base assembly for a total of four holes.)
 - Centers of holes are located 1 inch [25.4 mm] down from top of end plate and .53 inch [13.5 mm] from side of end plate.
 - Center to center of holes is 6-3/4 inches [171.5 mm]
2. With the threaded end to the inside, install four 5/16-18 x 1-1/4 inch hex head cap screws (9) through the 21/64 inch [8.3 mm] diameter holes.
3. Secure screws with four 5/16 inch flat washers (10), four 5/16 inch lock washers (11), and 5/16 inch hex nuts (12).
4. Position new cover on 5/16-18 x 1-1/4 inch hex head cap screws (9) and secure cover with four 5/16 inch flat washers (10), four 5/16 inch lock washers (11), and 5/16 inch wing nuts (13).

630-016 (2004-11)

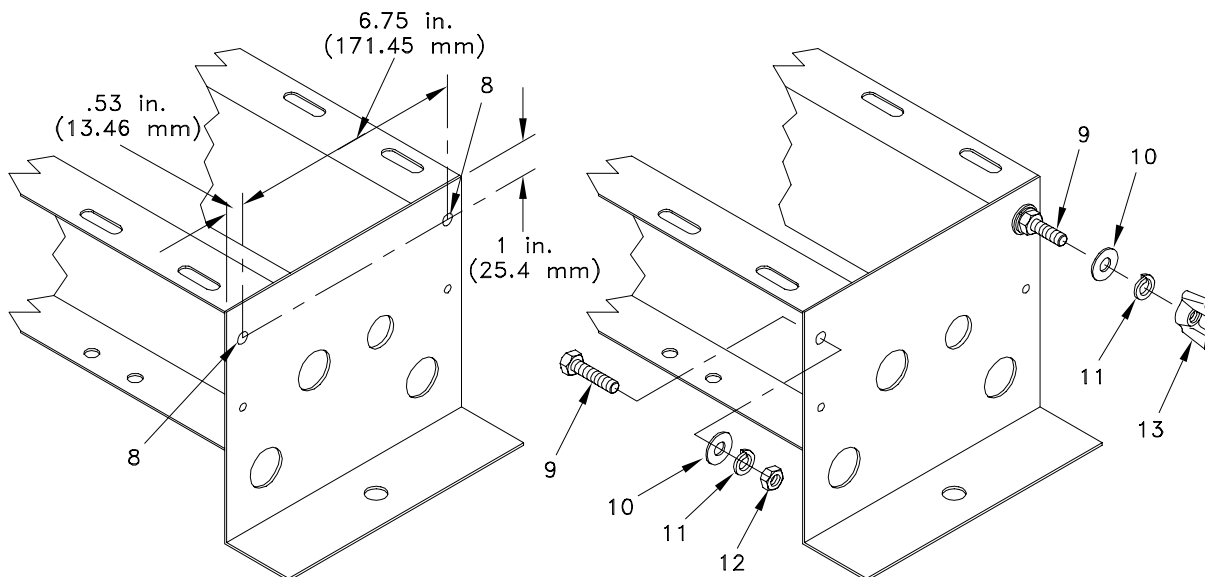

A606-009(7/97)

Verify microswitch cam settings

Closed loop door control requires only two switches on the door operator microswitch CAM. Verify the microswitch cams are set as follows.

- CL** CAM actuates CL (Close Limit) microswitch when the doors are in the desired fully closed position.
- OL** CAM actuates OL (Open Limit) microswitch when the doors are in the desired fully open position.

OPTIONAL CAM

- DSD** CAM actuates DSD microswitch when doors are approximately 4 to 6 inches from fully closed position when used with load balancing. CAM can also be set for other customer requirements.

F608-024 (9/98)

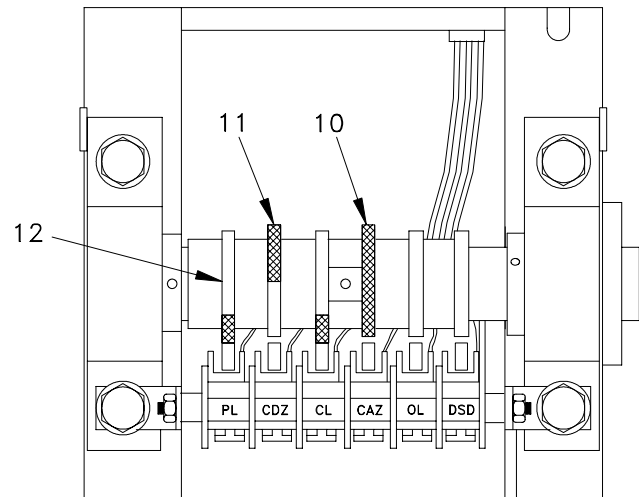

F608-059(3/96)

F608-028(3/96)

Wire closed loop door operator

Closed loop door control requires an input of 115 VAC. When this power is supplied from a transformer, transformer must have a rating of at least 500 VA.

1. Install and secure field wiring conduit (1) to appropriate knockout (2) in operator base.
2. Pull wires from elevator controller and connect to input and output terminals of terminal blocks TB2-TB6 (3).
3. Route switch cable (4) through one of top two knockouts (2) in door operator.

630-017 (2004-11)

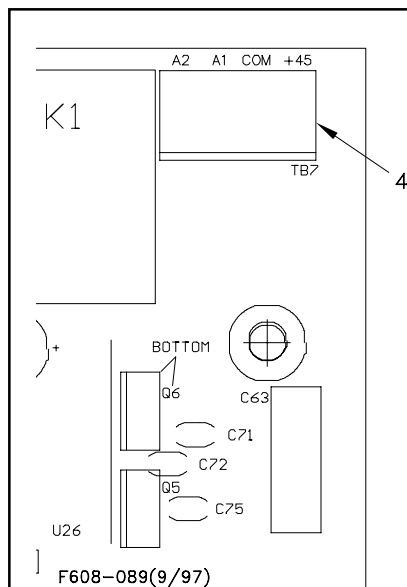
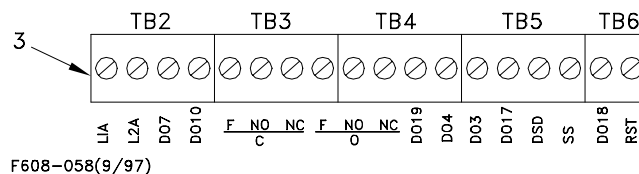
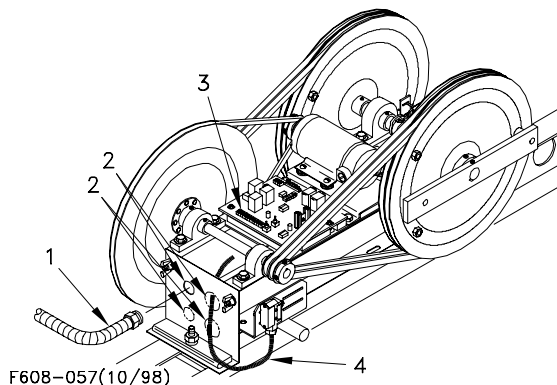

Verify TB7 (4) connections - Motor & DC supply

- A2 Motor connection - Red wire
- A1 Motor connection - Black wire
- COM DC power supply connection - Black wire
- +45 DC power supply connection - Red wire

F608-S15 (6/98)

INPUT & OUTPUT TERMINALS: TB2 - TB6

L1A to L2A	120 VAC @ 500 VA. If one of the input lines is grounded, it should be connected to L1A.	F NO NC	Auxiliary Signal to Close relay C switching contact. Designates a Form "C" contact on a relay that follows Signal to Close input, DO7.
DO7 to L1A	Signal to Close. When a relay contact across these terminals is made up, the doors close.	F NO NC	Auxiliary Signal to Open relay O switching contact. Designates a Form "C" contact on a relay that follows the Signal to Open input, DO10.
DO10 to L1A	Signal to Open. When a relay contact across these terminals is made up, the doors open. NOTE: this signal always overrides the Signal to Close.	DO19 to L1A	Auxiliary door profile. When a relay contact across these terminals is made up, doors open and close using heavy door profile.
DO17 to L1A	Close limit signal. A relay connected across these terminals de-energizes when the close limit microswitch is actuated. Relay is energized at all other times.	DO3 to L1A	Open limit signal. A relay connected between these terminals de-energizes when open limit microswitch is actuated. Relay is energized at all other times.
DO3 to DO10	Opening relay. A relay connected across these terminals is energized only when the doors are opening.	DSD to SS	Optional. Used on some projects for load balancing or other customer requirements.
DO7 to DO17	Closing relay. A relay connected across these terminals is energized only when the doors are closing.	DO18 to L1A	Future use. Do not connect anything to this input.
DO4 to DO7	Reduced Speed closing signal. When doors have a signal to close and a relay contact is made up across these terminals, the door closes at a reduced speed.	RST to L1A	Reset. A close switch contact between RST and L1A resets door operator.

F608-SI4 (9/98)

Verify TB1 (5) connections

Dual Transformers

Both L1A & both L2AX wires are paired together with black tape or wire ties

L1A Transformer connection - Black wire

L1A Transformer connection - Black wire

L2AX Transformer connection - Black wire

L2AX Transformer connection - Black wire

Single Transformer

L1A Transformer connection - Black wire

L2AX Transformer connection - Black wire

F608-S16 (6/98)

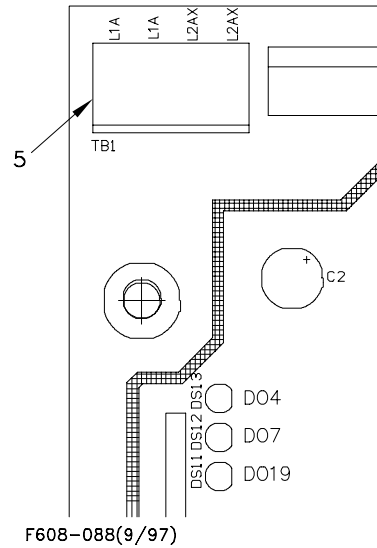

Checking operation

Complete operational checks as follows.

- Check switches
- Run “Learn” trip

CHECK SWITCHES

SW1 (1 RUN - TEST switch.

Puts door operator in RUN or TEST mode.
Use for LEARN mode and to run doors manually

SW2 (2) OPEN - STOP - CLOSE switch

Switch is active ONLY when RUN-TEST is in TEST position.

SW3 (3) Configuration for door operator.

Dip switches are only read at power-up or during a board reset.

RH

Down for a right-hand door, up for a left-hand door (looking out from inside cab.)

LRN

Up for normal operation, down for learn mode. (Used for initial door operator setup to learn open distance and closed position.)

Blank

Future use. Does not matter if switch is up or down.

CEN

Down for center opening doors, up for side-opening

F608-036 (6/98)

RUN “LEARN” TRIP

Before running “Learn” trip, manually open car door(s) 3 - 4 inches [76 - 102 mm]. Recheck all wiring and connections.

1. Move SW1 (1) into TEST position.
2. Move SW2 (2) into STOP position.
3. On SW3 (3), move dipswitch LRN (4) into DOWN position.
4. Make sure other dip switches on SW3 (3) are configured for door operator.
5. Apply power to board.
6. Check to see if LED 1 (7) and/or D18 (8) are on. If they are not on, continue procedure.
7. LED 2 (5) flashes at approximately 1 hertz.
8. Move SW2 (2) to CLOSE position.
9. LED 2 (5) goes out.
10. Doors go to closed position.
11. LED 2 (5) flashes twice as fast when door(s) are at closed position.
12. Move SW2 (2) to OPEN position.
13. LED 2 (5) goes out.
14. Door(s) go to open position.
15. LED 2 (5) comes on and stays on when door(s) are at open position.
16. On SW3 (3), move LRN (4) to UP position.
17. Move SW2 (2) to STOP position.
18. Move SW1 (1) to RUN position.
19. Press S2 (6) to reset door operator.
20. Door operator is ready for operation.

F608-037 (10/98)

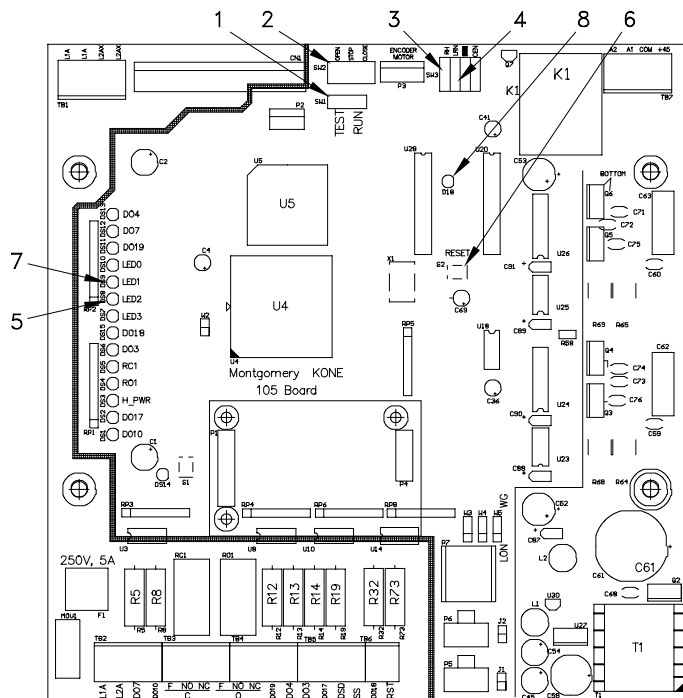

F608-065(9/98)

If LED 1 (7) and/or D18 (8) are on.

1. Press S2 (6) to reset board.
2. If LED 1 (7) or D18 (8) come on after reset, check all wiring.
3. If LED 1 (7) or D18 (8) are still on after checking all wiring, contact KONE Technical Support.

F608-S17 (2005-01)

Adjusting procedures for Closed Loop Door Control

**KONE Branch Offices: Refer to Adjusting
Procedures within PFM8-608 Door
Operator: Closed Loop**

**Customers purchasing from KONE Spares:
Refer to PFM8-631 Closed Loop Door
Operator Tool Instruction: when purchased
from KONE Spares**

NOTES

Version history

Checked by: John Princell
Approved by: John Brill

Date: 2005-01-05
Date: 2005-01-05

Issue	Date	Description of Change	PCR	Approved by
R0	2005-01-05	Creation date		John Brill
R1	2005-01-10	Revised pg. 17, and removed pg. 19 content		John Brill